

15 Amp 30 Volt H-Bridge Datasheet S24-15A-30V-HBRIDGE

Last Modified 2011-12-13

Acroname Robotics
www.acroname.com

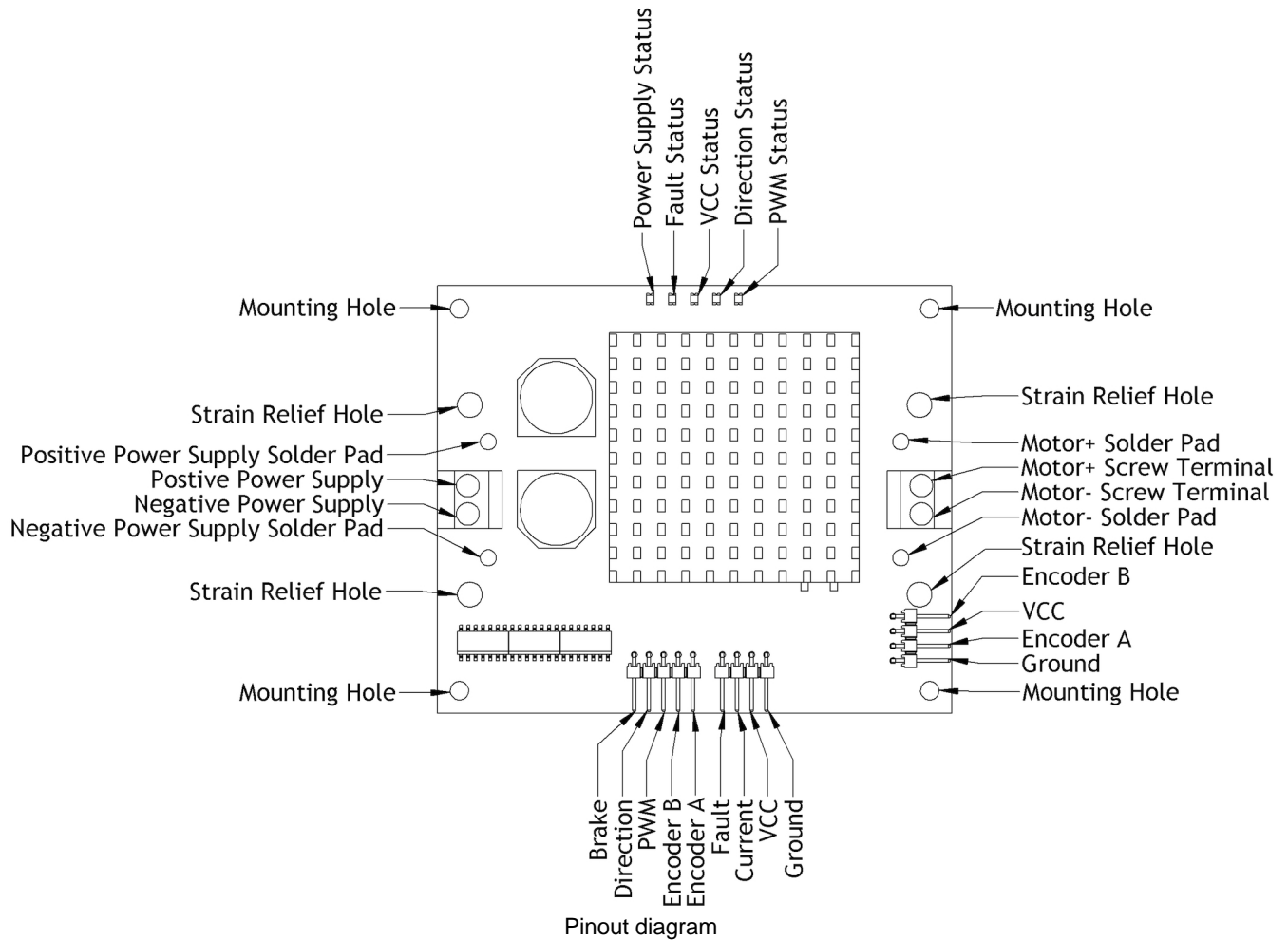

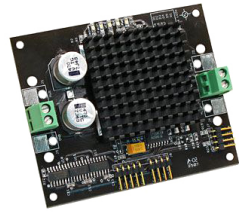
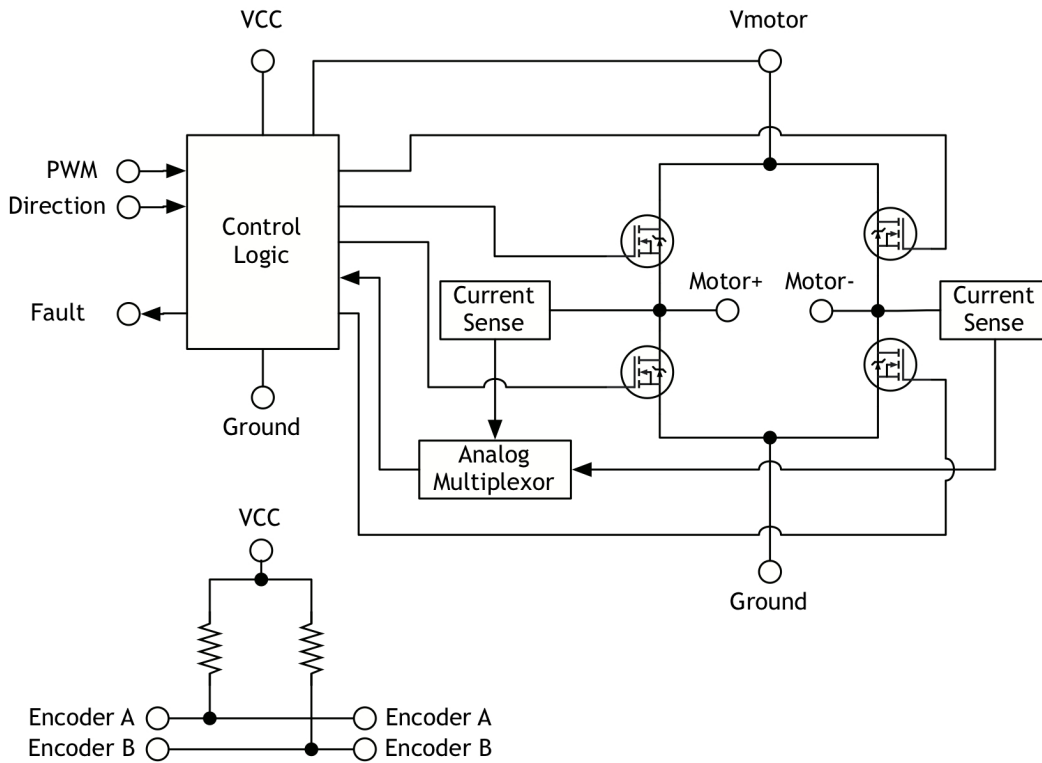

Functional Block Diagram

Recommended and Absolute Maximum Ratings		
	Recommended	Absolute Maximum
Motor Voltage Input	5.0V to 30.0V	5.0V to 35.0V
Continuous Output Current	15.0A	18.5A
Logic Supply Voltage	4.5V to 5.5V	-0.5V to 5.5V
Logic Supply Current		20.0mA
Combine MOSFET Power Dissipation		2.0W
MOSFET Junction Temperature		-55°C to 175°C
Storage Temperature		-40°C to 85°C

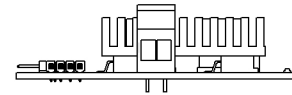
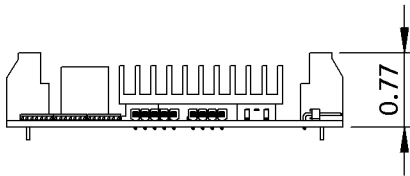
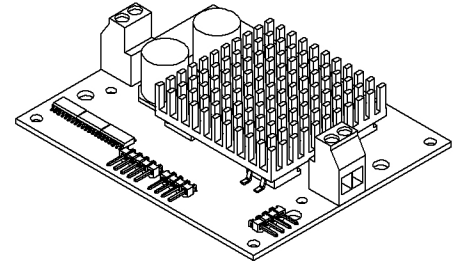
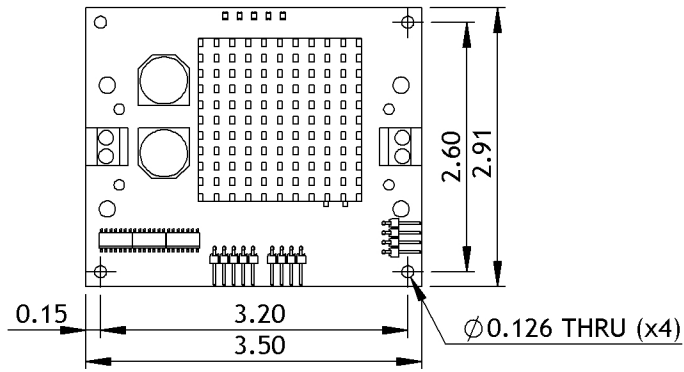

Dimensions are in inches.